

Splitter

Introduction

The Splitter is a Solutions series DIN rail mountable circuit. It is used to split a quadrature signal three ways at frequencies up to 250kHz. The A-channel is actually split five ways, additional outputs are for feedback and Puller remote. There is also provision for a product sensor and select.

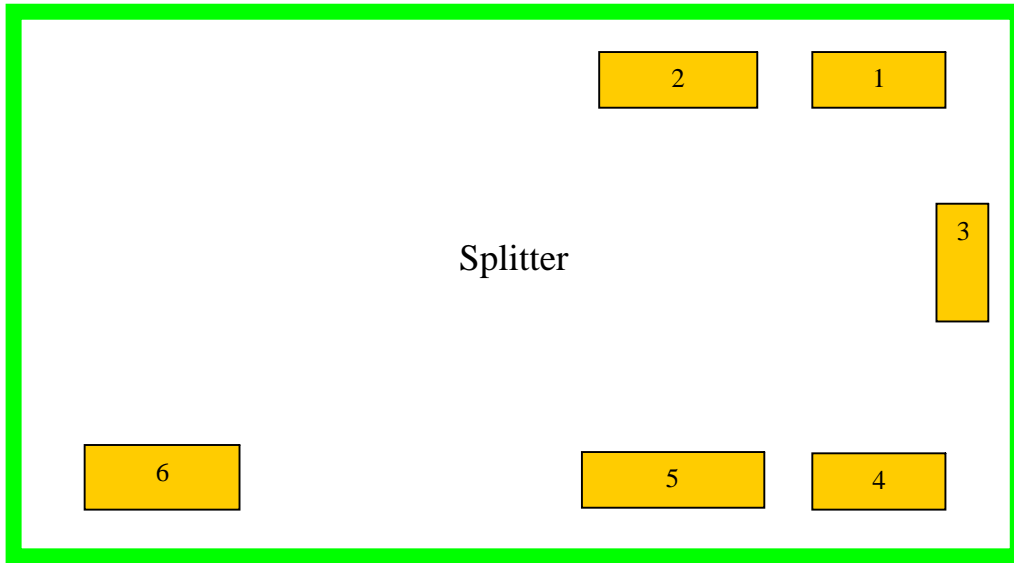

Connector 1 - Quadrature Input 5-way Connector

- A
- Anot
- B
- Bnot
- 0volts

Quadrature input. Channels A and B are opto-isolated inputs.

There are two opto-isolated balanced inputs on this connector and an optional reference point. The channels expect to receive a quadrature signal from an encoder, servo-simulated encoder or quadrature ring kit. Line driver signals such as RS-485 drivers can be connected directly to A, Anot, B and Bnot. Voltages between 3 and 24-volts are suitable.

Emerson E-Drive Connection

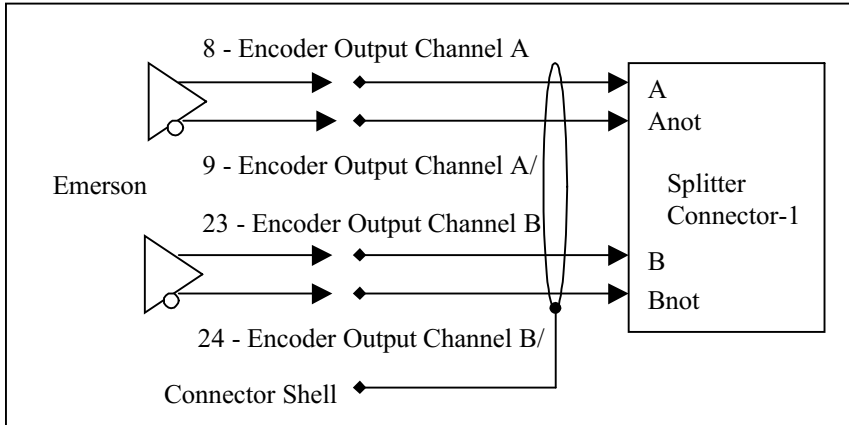

Quadrature Ring Kit Connection

Use the isolated 12-volts supply for the ring-kit.

Open-collector transistors can be used to drive these channels. This is done by connecting the transistor emitters to zero volts of the source circuit or the Splitter 0-volts reference point. The collector of each transistor should be connected to the “not” inputs. The positive inputs A and B should then be connected to a positive supply on the source circuit (3 - 24-volts) or the 12-volts reference on the 6-way connector (connector-2).

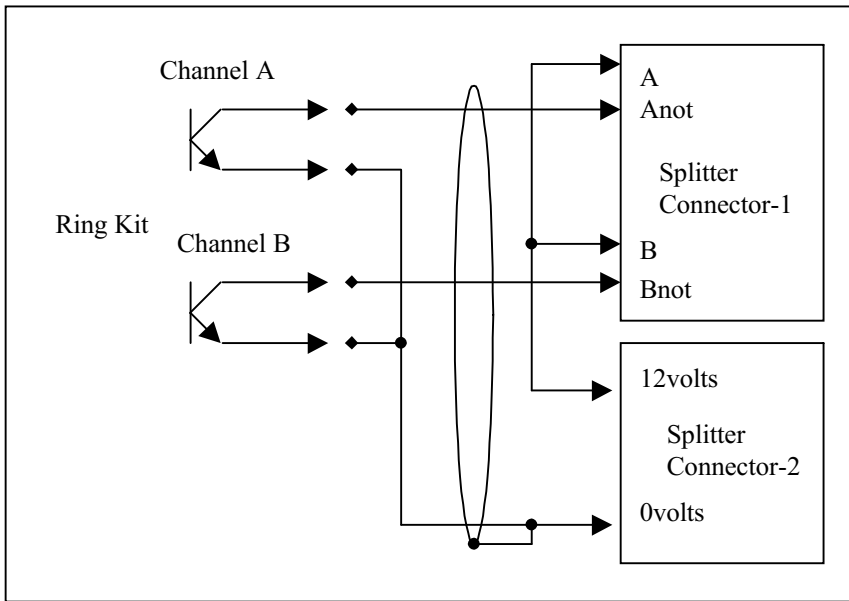

Connector 2

Feedback
 Feedback 0volts
 12volts
 Product
 0volts
 Product Select

The Feedback terminals are from an opto-isolated output transistor. This is available for a Fenner and is derived from the Quadrature input channel-A. This output is in phase with the input. You do not need to connect anything here for Emerson application.

Fenner Feedback Connection

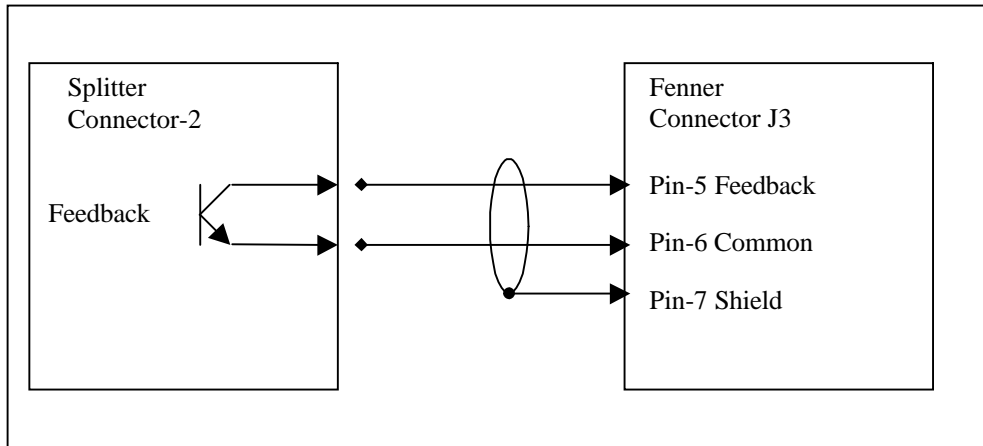

The 12-volts supply is isolated and is available to power up a product sensor. The Product Select should be connected to 0-volts to divert the product input to the B channels on connector 5. This also turns off the A channels at connector 5.

Product Connection

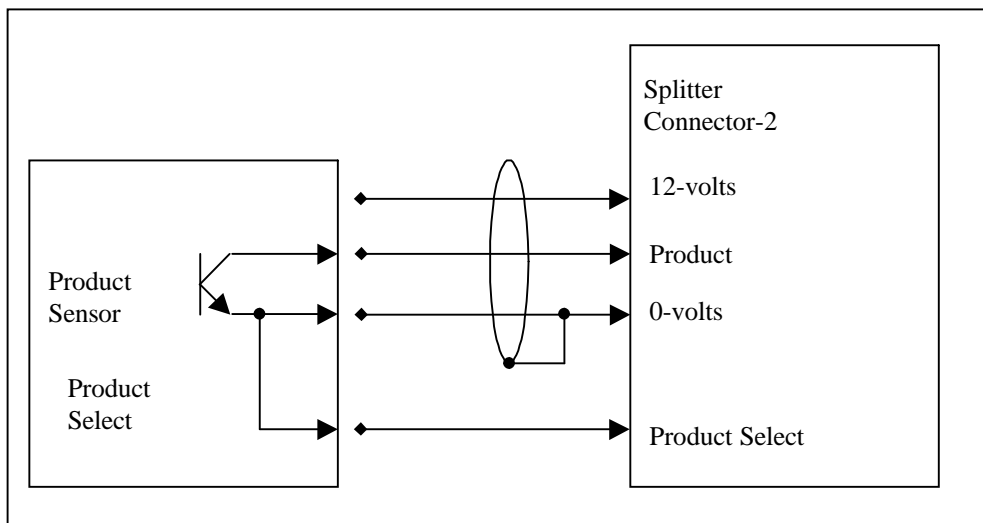

Connector 3

Signal
 5volts
 0volts
 12volts

This connector is used to power the Puller Master and Puller Remote (via a separate connector on the master). The channel-A signal is also available here. The Puller Master has a matching connector positioned so that the two circuits can sit side-by-side on the DIN rail. A simple 4-way to 4-way bridge joins these circuits together. Product select does not turn off the velocity signal.

Connector 4

A
 Anot
 B
 Bnot
 0volts

Isolated Quadrature output. This can be used for third party requirements. When using puller select these outputs continue to echo the quadrature encoder signal. These drivers are RS-485 equivalent.

Third Party Connection

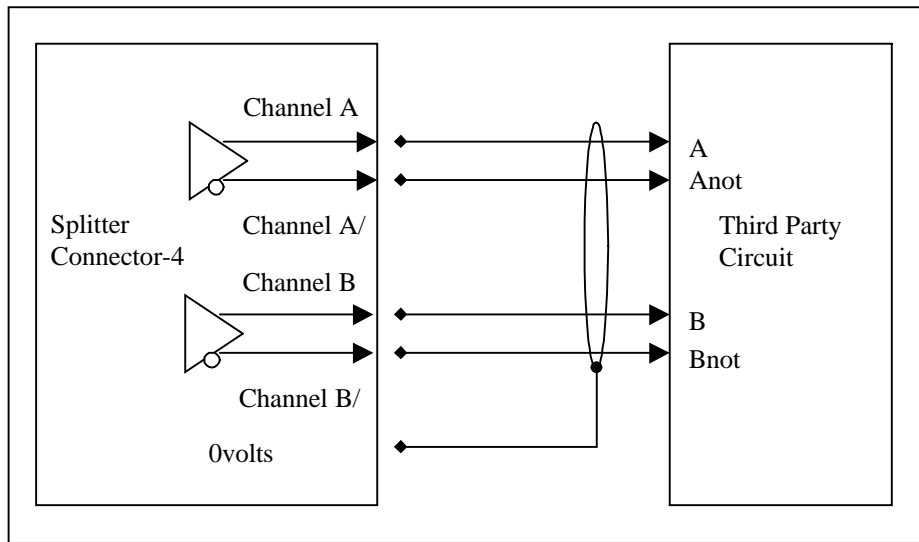

Connector 5

- A
- Anot
- B
- Bnot
- 0volts
- A Open Collector
- B Open Collector

Quadrature output. The line driver outputs can be used to connect to an LE-650 or LE-650s revision-4 control. The 0-volts reference is isolated but is also the reference for the Splitter and Puller remote circuits. This could be grounded if desired. These drivers are RS-485 equivalent.

LE-650 and LE-650s Revision-4 Connection. (LE-850).

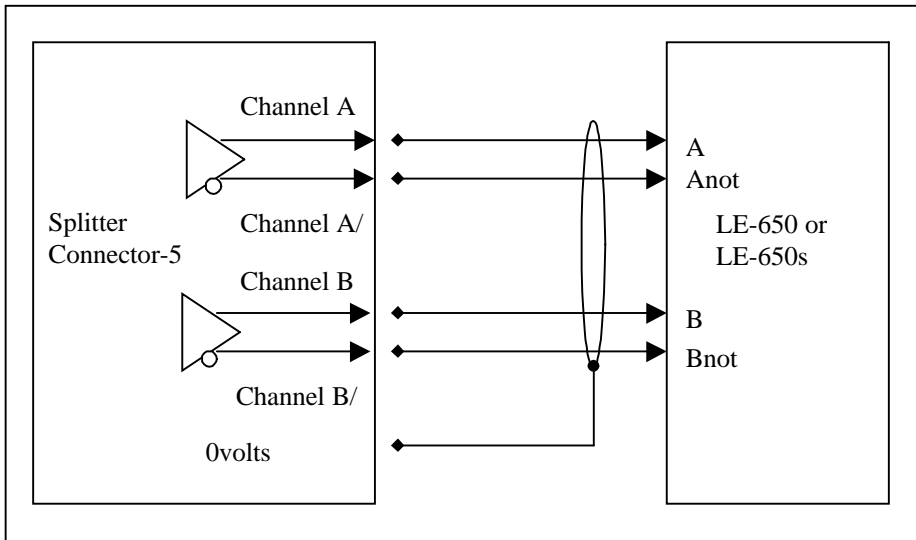

The Open Collector outputs can be used with older LE-650 and LE-650s revisions. When using open collectors use the 0volts as reference.

LE-650 and LE-650s older Revisions Connection.

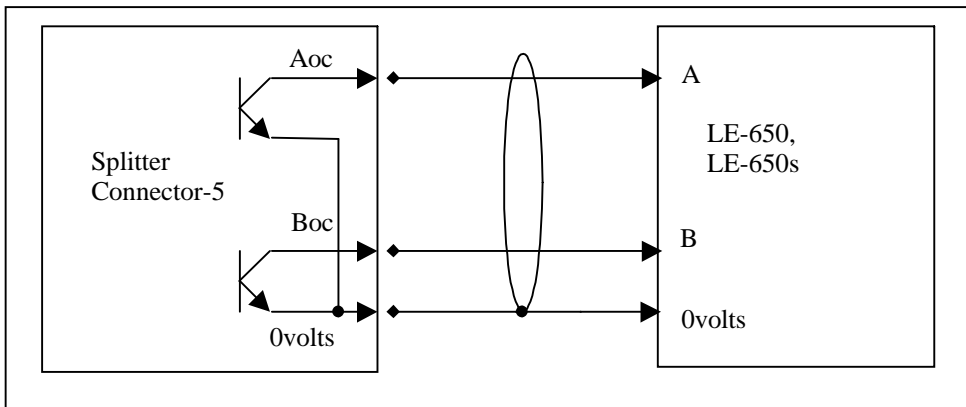

Product select turns off channel A and routes the Product sensor to channel B. There is no phase inversion.

Connector 6

L
N
E
E

This connector is for 120-volts AC supply. Pin-outs are exactly the same as on PAVC's, 650's etc. The fuse is rated 250mA anti-surge.

Puller Master**Introduction**

The Puller Master is a Solutions series DIN rail mountable circuit. It is powered by the Splitter circuit mentioned earlier. This circuit reads the signal frequency provided by the Splitter and converts the frequency received into Feet per minute. Switches are used to set the sample rate. The speed information is sent to the Puller Remote for read-out via an RS-485 communication link using 9,600-baud, 8-data bits, 2-stop bits, half-duplex. The Puller remote can be used to turn on two outputs for up and down remote speed adjustment.

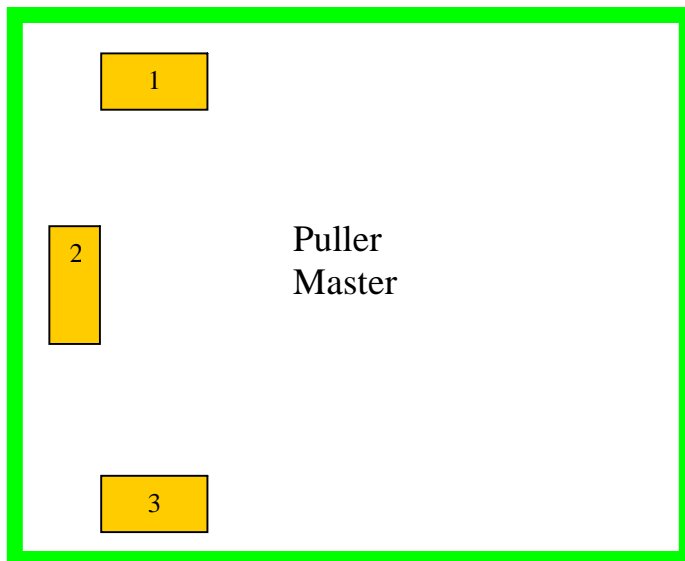
**Connector 1**

Up+
Up-
Down+
Down-

These are isolated outputs that can be used with the Fenner or Emerson.

Fenner Connections

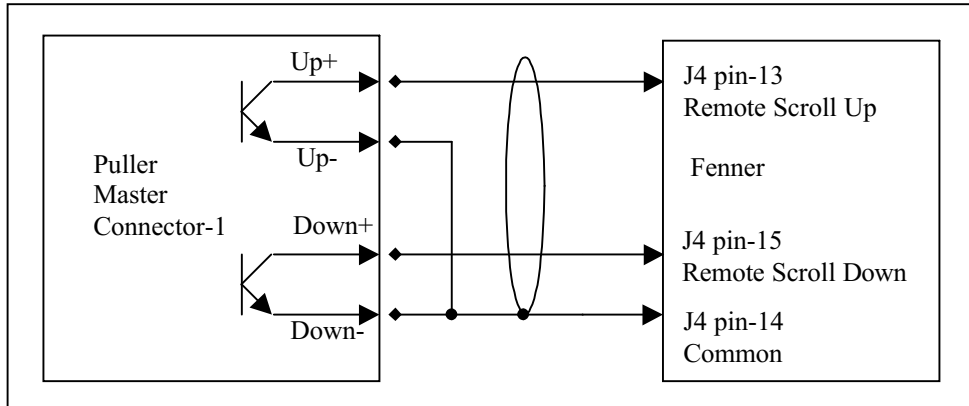

For Fenner the negative terminals are connected to the Fenner common and the positive terminals are to be connected to Fenner up and down inputs.

Emerson E-Drive Connections

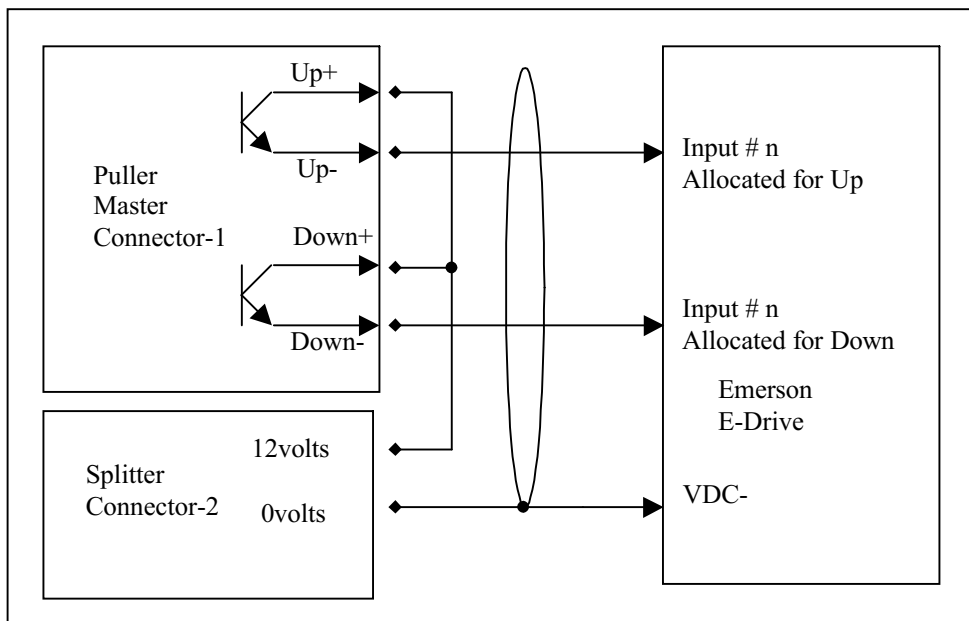

For Emerson the positive terminals should be connected to the positive reference of the Splitter. The negative terminals are then connected to the Emerson inputs allocated for up and down.

Connector 2

- Signal Violet
- 5volts Red
- 0volts Green/Yellow
- 12volts Orange

This is the connection that joins to the Splitter. It is 4” long.

Connector 3 - connects to the Puller Remote via a 4-pin XLR

12volts	Red	to pin 4 XLR socket	Pair1
0volts	Black	to pin 3 XLR socket	Pair1
B	Green	to pin 2 XLR socket	Pair2
A	White	to pin 1 XLR socket	Pair2

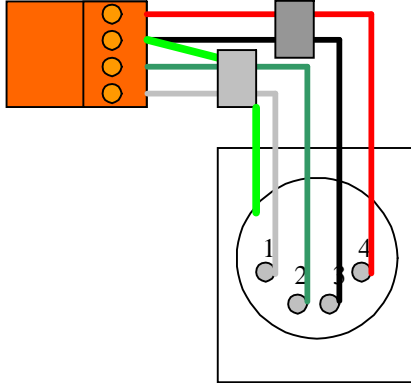

Internal cable harness 12" long.
External cable 50ft long or length as required.

Setting up

Switches are numbered 1 to 6 and are known as hexadecimal switches. Each has sixteen positions marked 0 to 9, and A to F.

Switch 6

Switch 6 is used first to select Fenner or Emerson. The table below shows the required read-out when the motor is running at maximum speed. If the motor is set at a lower speed then the minimum and maximum values will alter by a similar ratio. For example: if an Emerson drive is to run at 75% of its maximum speed then setting 3 would be (640.0×0.75) to $(2,560.0 \times 0.75) = 480$ to 1,920-FPM.

Switch	Option	Minimum	Maximum
0	Emerson	80.0	320.0
1	Emerson	160.0	640.0
2	Emerson	320.0	1,280.0
3	Emerson	640.0	2,560.0
4	Emerson	1,280.0	5,120.0
5	Fenner	43.7	175.0 *A to F will select this option
6	Fenner	87.5	350.0
7	Fenner	175.0	700.0
8	Fenner	350.0	1,400.0
9	Fenner	700.0	2,800.0

Switches 1 to 5

Switches 1 to 5 set the sample rate in microseconds. Switch 5 is the most significant digit and switch 1 the least significant. The minimum setting is 40000.

Initially set these 5 switches to 8 (half-way). Run the puller at maximum speed as set using a calibrated tachometer.

Adjust the switches to give the desired read-out. Switch 5 has the coarsest adjustment. It should be set first. Turn switch 5 to the point where the read-out is just below that required, i.e. the next position sets the read-out too high.

Next turn switch 4 (which has a sixteenth of an effect than switch 5) to its optimum position.

Gradually go through switches 3, 2 and 1 in the same way. Allow settling time after each adjustment.

Puller Remote

This connects to the Puller Master via the 4-pin XLR and 4-way board connector. Two of the connections are for power (12-volts DC) and the other two connections are for RS-485 half-duplex communications (9,600 baud, 8-data bits, 2-stop bits). Speed information is received from the Puller Master and switch status is returned.

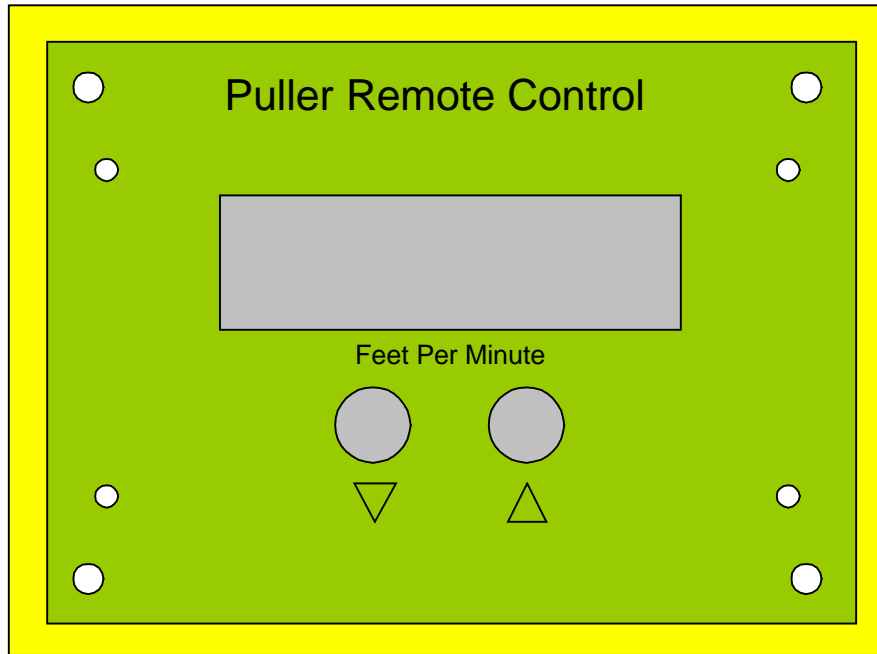

**Connector 1
(inside remote)**

12volts	Red	Pair1
0volts	Black	Pair1
B	Green	Pair2
A	White	Pair2

